

# Instruction Manual AEA COMPUTER PATCH MODEL CP-1

## INFORMATION TO USER\*

This equipment generates and uses radio frequency energy and if not used and installed properly, that is, in strict accordance with the manufacturer's instructions, may cause interference to radio and television reception. It has been type tested and found to comply with the limits of a Class B computing device in accordance with the specifications in Subpart J of Part 15 of FCC Rules, which are designed to provide a reasonable protection against such interference in a residential installation. However, there is no guarantee that interference will not occur in a particular installation. If this equipment does cause interference to radio or television reception, which can be determined by turning the equipment off and on, the user is encouraged to try to correct the interference by one or more of the following measures:

Reorient the receiving antenna.

Relocate the computer with respect to the receiver.

Move the computer away from the receiver.

Plug the computer into a different outlet so that computer and receiver are on different branch circuits.

Operation of CP-1 without shielded cables may void compliance with Class-B certification.

If necessary, the user should consult the dealer or an experienced radio/television technician for additional suggestions. The user may find the following booklet prepared by the FCC helpful:

"How to Identify and Resolve Radio-TV Interference Problems"

This booklet is available from the US Government Printing Office, Washington DC 20402. Stock No. 004-000-00345-4.

\*This notice is NOT effective if checked here: \_\_\_\_\_

Copyright 1983 by **ADVANCED ELECTRONIC APPLICATIONS, INC.**  
All rights reserved. No part of this book may be reproduced or utilized in any form or by any means, without permission in writing from the publisher.

# Instruction Manual AEA COMPUTER PATCH MODEL CP-1

## TABLE OF CONTENTS

DESCRIPTION .....	1
CONTROLS.....	2
CONNECTIONS.....	3
OPERATION .....	5
RF SHIELDING.....	7
BASIC RTTY THEORY.....	8
SCHEMATIC .....	10
TROUBLE SHOOTING GUIDE.....	12
ALIGNMENT PROCEDURE .....	13
IN CASE OF DIFFICULTIES .....	14
BLOCK DIAGRAM .....	15
PARTS PICTORIAL.....	16
PARTS LIST .....	17
APPENDIX "A" .....	19
APPENDIX "B" .....	20
APPENDIX "C" .....	21
APPENDIX "D" .....	22
APPENDIX "E" .....	23
WARRANTY	

## **AEA COMPUTER PATCH™ INTERFACE MODEL CP-1**

Congratulations on your decision to purchase the AEA Computer Patch™ interface. This equipment was designed to broaden the scope and use of the radio amateur's home computer.

### **DESCRIPTION**

The AEA Computer Patch (CP-1) provides the electronics necessary to connect a personal computer such as the Commodore, Apple, Radio Shack, etc. to your amateur station. The CP-1 uses your receiver audio teletype or CW signals to generate TTL or RS-232 signals for your computer and it generates microphone level AFSK signals for teletype transmissions. For CW transmissions, positive and negative keying lines are provided. A send-receive line for the transmitter push to talk (PTT) circuits is included for automatic transmit-receive.

Specific applications software packages for the CP-1 are available for many of the popular personal computers on the market. Contact your dealer for information regarding software for your particular computer.

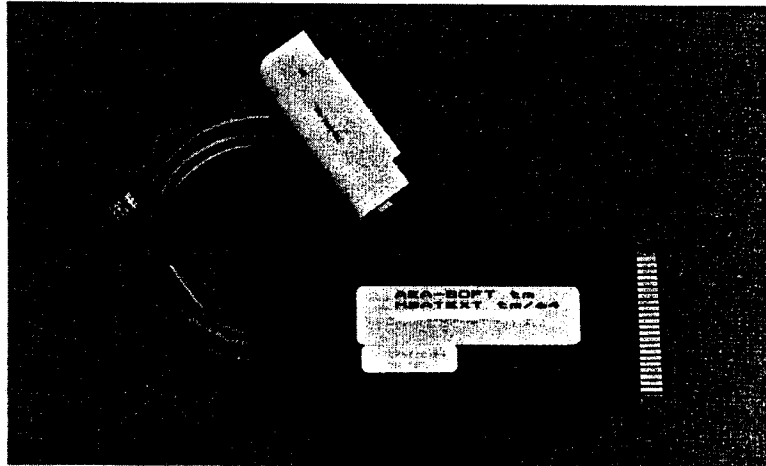

Optional MBATEXT™ Software Package (for Comm-64)

## CONTROLS

### FRONT PANEL

**Power.** On/off switch. With the switch depressed, the CP-1 will be on and the LED power indicator will light.

**Filter.** VAR/170/CW — Selects CW or RTTY operation. Use the VAR (variable) shift rotary control when in the VAR position for RTTY shifts at other than 170 Hz. The variable shift control covers frequency shifts between 100 Hz and 1000 Hz. It is used for tuning non-amateur RTTY signals. Normally, when using your CP-1 in the amateur bands, use the 170 position. CW selects a 800Hz center frequency filter.

**Normal/Reverse.** In the normal position 2125 Hz mark and 2295 Hz space are selected. In reverse, 2295 mark and 2125 space Hz tones are selected. This feature only affects receive. If you select reverse, your transmitted tones will still be 2125 Hz mark and 2295 Hz space. The reverse mode is useful for copying stations that are inadvertently transmitting inverted.

**Tune.** Magic eye style bar graph indicator for CW and RTTY signal tuning.

**VAR Shift.** Adjusts RTTY shift of upper frequency tone from 100 Hz to 1000 Hz. This control is only effective when the VAR filter is selected.

**STBY/PTT, Manual TX.** This control will allow you to manually activate the PTT line of your transceiver, (provided you have hooked up a cable between the mic output of the CP-1 and the mic input of your transceiver). When the switch is in the 'in' position, your transceiver will be in a transmit state.

### REAR PANEL

**Threshold — Squelch Adjustment.** Sets minimum signal level for CP-1 operation. This control only affects RTTY reception. It can be used as an anti-space circuit (so you only get print when you are receiving a RTTY signal). To set the level, tune to a dead air spot on the band and turn the control full clockwise viewing the unit from the back. With the RTTY filter selected on the CP-1, slowly start turning the 'threshold' control counter-clockwise. When garbled copy starts appearing on the screen, turn the control a bit clockwise.

**Note:** Your volume control should be set at an easy listening point. If you have it set too high or have too much line noise, you may not be able to completely eliminate garbage copy under no-signal conditions.

**AFSK Level.** Sets the AFSK output level. The level is variable between 0 and 200 mv pp. For transceivers with pre-amplified microphones (such as ICOM), set the control at maximum signal out. The level is preset to 30 mv pp. If more output is required, reduce R116 value, but no lower than 560 ohms.

## CONNECTIONS

### POWER

The CP-1 requires a 12-16 VAC power source (supplied with unit) capable of supplying 400 ma. The power connector is a 2.1 mm center pin coaxial type.

### AUDIO

The audio IN/OUT jacks are 3.5 mm phone jacks and are in parallel in the CP-1. The audio IN (input) jack is used to provide the CP-1 with audio (CW, RTTY) signals from the transceiver. Receiver audio should be taken from the external speaker output of your receiver. Do not draw audio from the headphone, tape out, or phone patch out jacks; because frequently, manufacturers will install some resistance in the leads to cut down audio level or impedance match.

### KEY IN

Straight key, or **positive** keyer input. In the CW mode, this input keys the + and - keying transistor switches. In the RTTY mode, it generates narrow shift AFSK (about 50 Hz) for CW identification in RTTY. It is also useful for Morse sending practice by monitoring your fist on the CRT attached to your computer (providing you have Morse receiving software). This input is only active when the CP-1 is turned on.

### SCOPE OUT

The mark and space filter outputs are provided at these connections for tuning RTTY signals with the aid of an X-Y scope.

### KEY OUT/ +, -

The + and - keyed outputs are for CW keying of the transmitter. The + key output is for use with transistor (direct) keying. The key output is for use with transmitters using grid block keying. Connect a line from one of these jacks to the key/input on your transceiver. If you do not know whether your rig is + keyed or - keyed, then simply insert the cable into either the + or the - key outputs. If you suddenly hear your side tone go on and stay on, then insert the cable into the opposite key out jack. Remember to place your mode switch on your radio in the CW mode when performing this test.

### DEMOD OUT

TTL level low on space tone or CW (0v). High mark tone or lack of signal (5v). This output can also be used to drive a current loop circuit. Appendix A shows a loop keying circuit that will perform the task of driving a current loop. If you wish, you could also purchase the AEA model RS-232-1 option that will perform as an isolated current loop keying circuit.

## TTL (Also see RF Shielding, page 7)

To computer, 5 pin connector (supplied), TTL levels

- Pin 1 - PTT; active low send
- Pin 2 - RTTY input; space low, mark high
- Pin 3 - CW input; active low
- Pin 4 - Ground
- Pin 5 - Demodulator output; space low, mark high

**Note:** This connector is wired with Pin 5 being on the left hand side of the connector viewing the unit from the rear.

## RS-232 I/O (OPTION)

Provides RS-232 level demodulator output and RTTY or CW input. Internal jumpers provided for 'terminal' or 'computer' drive. This is strictly an RS-232 level shift, it will not drive a printer or other such devices, as the CP-1 is strictly a modem. It has no software for built-in conversions.

## TRANSCEIVER OUTPUT:

This connector handles all of the 'interfacing' to your transmitter

- Pin 1 - AFSK out—Audio Frequency Shift Keying. This line is connected to the (mic) audio input of your transceiver.
- Pin 2 - PTT out. This is connected to the high side of the PTT line of your transceiver. Wiring examples are given in Appendix B for some of the more popular transceivers. If you have a transceiver with negative PTT (such as the Drake T4XC) then follow Appendix C.
- Pin 3 - PTT GND. This is connected to the PTT ground side of your transceiver. Some transceivers require a separate ground and others do not. If yours does, then wire up pin 3 to your PTT ground side. If yours does not, do not wire up pin 3.
- Pin 4 - Shield. This is the shield of the audio lead. Connect to the ground pin of your mic connector. This pin also normally serves as the ground side of your PTT circuit. See above (Pin 3).

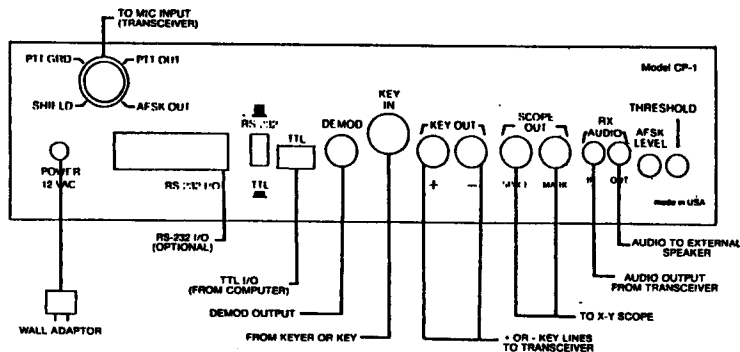

REAR PANEL CONNECTIONS

## OPERATION

There are three filter selections available from the front panel. Two are for RTTY teletype use, one is for CW use. The position marked 170 is for use with amateur and commercial 170 Hz shift teletype (either Baudot or ASCII) with the mark tone at 2125 Hz and the space tone at 2295 Hz. In the VAR position, the space tone filter is tunable with the VAR shift control from 2225 Hz to 3125 Hz giving a frequency shift range of 100 Hz to 1000 Hz.

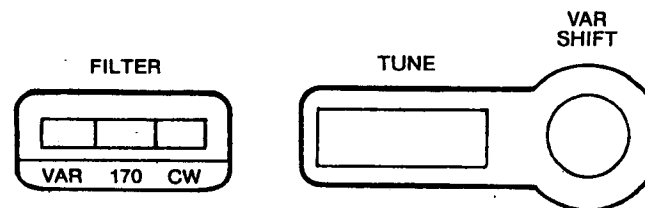

## CW

Press the front panel filter switch CW position. This selects the 800 Hz CW input filters and the positive and negative transmitter keying circuits.

Set your receiver audio to a comfortable level and tune in a CW signal for maximum closure. What we mean by maximum closure is that you are getting peak closure of the bar graph display. If you set your volume at a particular level and tuned across a signal and the bar graph closes to a maximum of 8 LED's, the peak closure is 8 LED's. If you turn your volume up, the closure may be 10 LED's, however, when driving the CP-1 with a very loud signal; it is possible to over drive the filters with noise. It is best to run just enough audio to get the job done, 6 to 8 LED's is about right. If you see the bar graph flicker with just noise on the frequency, then you probably have the volume up too high.

Some software programs will automatically activate the PTT line when you place the program into transmit. If yours does not, use either the Manual RX/TX Switch on the front of the CP-1 or a foot switch.

## TELETYPE RECEIVE

Both VAR and 170 switch positions are used for teletype (Baudot or ASCII) operation. Pressing either of these switches selects the teletype filters and disconnects the CW keying lines from the CW keying transistors.

Most amateur teletypes use standard 170 Hz tone spacing (2125 Hz mark, 2295 Hz space tones). Use the 170 position for standard amateur operation.

To tune amateur HF teletype signals, set your receiver to lower sideband, set the audio to a comfortable level and slowly tune your receiver for a teletype signal. Tune for peak bar graph closure and minimum flicker. If the LED bar graph flickers on mark-space transitions, retune until the flickering stops.

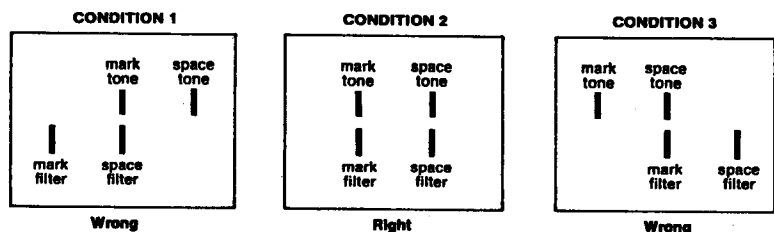

When you tune your receiver dial, you want to match the RTTY mark and space tone frequencies up with the respective bandpass filters in the CP-1, as indicated in condition 2. This proper tune condition will be indicated by the magic-eye style bar graph indicator display with a peak closure of no more than 6 or 8 bars lit (back off on the volume if you have more) and no blinking as the tones shift back and forth. You will get a false tuning indication as shown in conditions 1 and 3, if a peak closure results in a blinking display as the tones shift back and forth. With practice, you will learn to lock onto a properly tuned condition very quickly and you will gain a deep appreciation for our unique tuning indicator.

For shifts other than 170 Hz, use the VAR position. The VAR position uses the VAR shift control to adjust for tone shifts between 100 Hz and 1000 Hz. To use the variable position, first depress the VAR button, turn the variable shift control full clockwise and tune across the unknown RTTY signal. Watching the bar graph, tune to the lower pitch frequency of the two tone RTTY signal. Tune so the LED bar graph is at peak closure, but flickering. Now adjust the variable shift control counter-clockwise until you achieve peak closure with no flickering.

## NORMAL-REVERSE SWITCH

Some stations use reverse mark and space tone frequencies, usually accidentally. If you are sure of the speed and shift of the received station and receiving 'garbage', try the reverse position.

## TELETYPE TRANSMIT

If you are using the RS-232 option, you may have to manually switch your transceiver to transmit. Again, this depends on your particular software. The normal computer TTL inputs can be used for automatic send/receive switching under software control. The 'AFSK out' level may be adjusted with the rear panel AFSK level control. This level is preset to 30 mv pp, however, it can be adjusted to 200 mv pp for those of you who own rigs with a preamp mic such as the ICOM transceivers.

If you own a transceiver with a RTTY mode position, then you may desire to modify your CP-1 as per Appendix D to use FSK. If you wish to use AFSK, then you must use lower sideband and use the mic input of the transceiver. For those of you who wish to use 850 Hz shift on transmit, refer to Appendix E on how to modify your CP-1.

## 300 BAUD OPERATION

The low pass filter is optimized for CW and RTTY rates less than 100 baud. To use 300 baud, parallel R77 with a 16 K ohm ¼ watt resistor.

## WARNING

Most amateur transmitters are NOT capable of 100% duty cycle full power input on Radio Teletype (RTTY) transmission). If your transmitter manual does not have operating instructions for RTTY, we suggest one-third to one-half the normal CW input power level. Be sure to disconnect your microphone to prevent sounds in the shack from being transmitted.

## CW IDENTIFICATION

In teletype operation the AFSK mark and space tones are 2125 and 2295 Hz, respectively. If the CW input line is activated during RTTY operations, a narrow shift (approximately 50 Hz) AFSK CW signal is generated. This can be used for narrow shift CW identification.

## RF SHIELDING

The CP-1 has been designed and tested to comply with FCC rules for a class-B computing device under specifications outlined in part 15, subpart J.

The CP-1 is far better than the FCC requirements because of the necessary close proximity of HF receiving equipment. To assure maximum rejection of RF interference, be sure to use only well shielded interface cables between the CP-1 and your computer and transceiver.

If computer "hash" is present after using shielded cables, try changing the physical location of the computer and/or CP-1 relative to the receiver. Under particularly difficult situations, try placing the CP-1 and computer on a different 110 VAC circuit from the one your transceiver is using.

**NOTE:** To avoid interference with other electronic equipment in your home or other's homes, make sure you make or procure cables which are shielded, and have the shield connected to ground. AEASOFT™ software cables are recommended and have the needed shield.

## BASIC RTTY THEORY

Radioteletype (abbreviated RTTY) is a form of telegraphic communication employing typewriter-like machines for generating a coded set of electrical impulses when a key is pressed on the keyboard and converting a received set of such impulses into the corresponding character.

With the application of home computers to the amateur's use, we are now able to use a computer to do all decoding and generation of the coded set of electrical impulses. Further, computers require practically no maintenance, whereas old teletype gear required frequent oiling and maintenance.

More important than the computer, is the terminal unit (TU) which handles the conversion of the two-toned signal into a string of DC high and low (1 or 0) level signals. This is called a demodulator because it demodulates the tones into something the computer can understand. A TU should also have some method of generating a two-tone signal from a high/low going signal. This is called a modulator. When a demodulator and modulator are combined into the same package, it is referred to as a modem.

The CP-1 is a modem. The demodulator in the CP-1 employs a sophisticated dual filtering system and an automatic threshold circuit. The two tones (received from the air) are separately demodulated and then fed into a threshold circuit. The threshold circuit then automatically decides which is the stronger of the two filter signals and allows that one to pass. However, when one of the signals fade out or is jammed or removed altogether, the threshold circuit automatically switches over to the clear tone.

This sort of a system is especially nice under poor signal conditions when a condition called selective fading is present. Selective fading is when one of the RTTY tones fades away and then reappears. When this happens, the threshold circuit automatically adjusts to the other tone. Another nice feature of the threshold circuit is if interference eliminates one of the RTTY tones or if one of the tones is jammed, the threshold circuit will again switch over to the tone remaining in the clear.

It is obvious that a dual filtering system which uses both filters and a threshold circuit, will perform much better than a single filter system or a phase-locked loop system that uses only one filter for decoding.

U.S amateurs are allowed to use 60 wpm, 67 wpm, 75 wpm, and 100 wpm Baudot, and 110 baud and 300 baud ASCII on the HF bands. ASCII is a code made up of 7 bits and 1 parity bit. However, the parity bit is left out. Baudot is made up of a 5 bit code and includes a start bit and stop bit. The start bit sets the sending and receiving mechanism in

operation. The stop bit indicates the end of the operation (character) and sets the machines up for the next character. Since both RTTY Baudot and RTTY ASCII are teletype sent over a radio, technically both are RTTY. However, RTTY Baudot is usually referred to as RTTY and RTTY ASCII is referred to as ASCII. In this manual when we say RTTY we mean both Baudot and ASCII. This may sound a bit confusing, but if you just remember that both are 'radio teletype' that are made up of different codes; you should not remain confused for too long. Most amateurs you find will be running 60 wpm (45 baud). (A baud is defined as the number of pulses per second). The North American standard is to use mark as 2125 and space as 2295 (for a shift of 170 Hz). Generally, a good place to find RTTY/ASCII signals is on the 20 meter band between 14.080 and 14.100. The best thing to do is listen in on some QSO's in action and see how they operate before getting on the air yourself. To do this with the CP-1 you must use lower sideband and use AFSK (Audio Frequency Shift Keying). You who have a rig with a RTTY position on your mode switch may want to use FSK (Frequency Shift Keying). The CP-1 is set up for AFSK, however, you can modify it to do FSK (see Appendix D). The CP-1 has an internal AFSK generator. This is called the modulator. It generates the two-tone signal upon command. This signal is then fed to your microphone input on your transceiver.



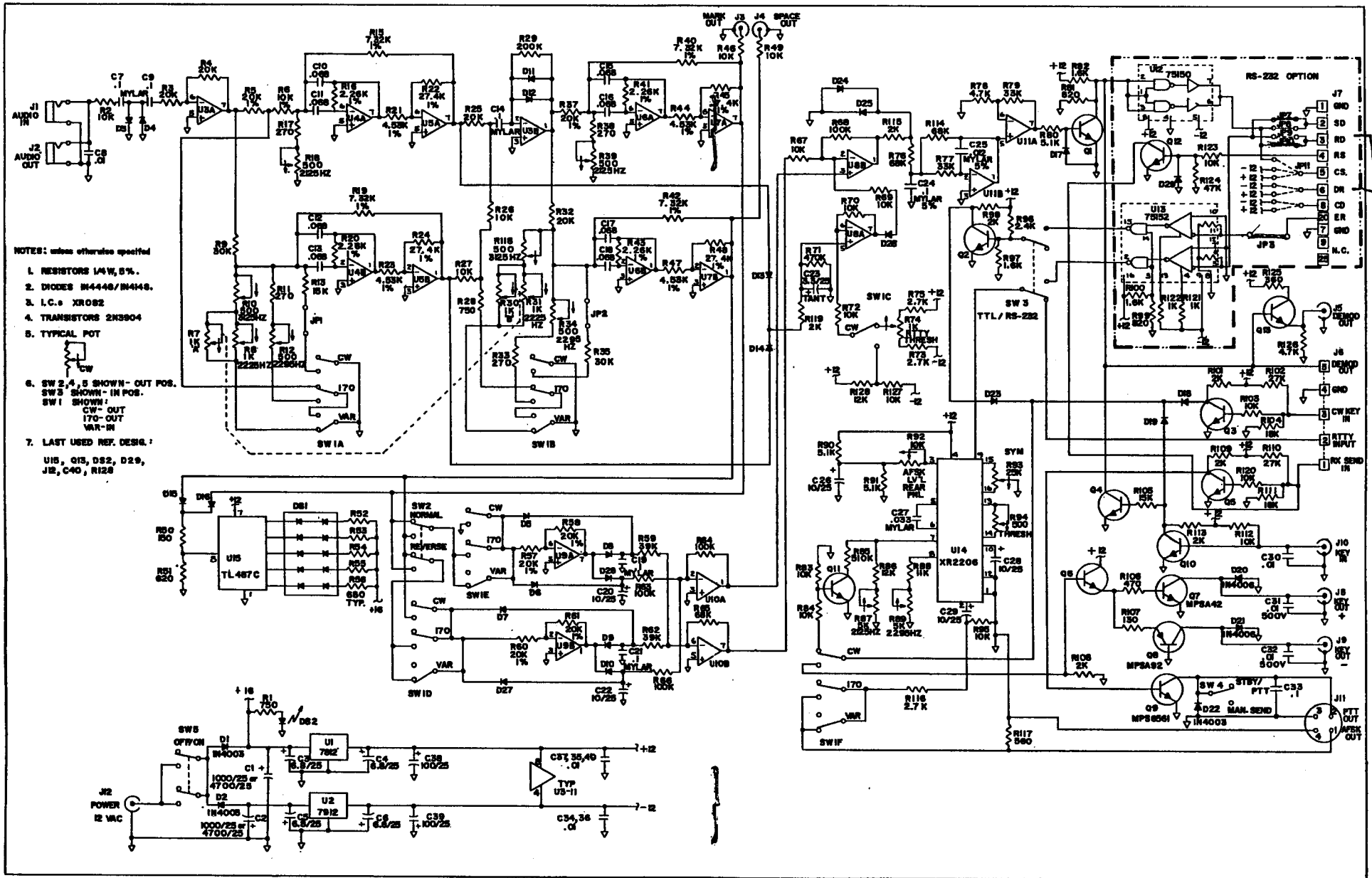

**SCHEMATIC**

# TROUBLE SHOOTING GUIDE

PROBLEM	CAUSE	SOLUTION
No Power	<ol style="list-style-type: none"> <li>Unit not turned on</li> <li>Unit not plugged in</li> <li>No power from wall adaptor</li> </ol>	<ol style="list-style-type: none"> <li>Turn unit on</li> <li>Plug unit in</li> <li>Check supply for 16 VAC</li> </ol>
Bar graph won't flicker	<ol style="list-style-type: none"> <li>Audio input connection incorrect</li> <li>Transceiver not turned on</li> <li>Volume too low from transceiver</li> <li>Incorrect tuning of transceiver</li> </ol>	<ol style="list-style-type: none"> <li>Re-connect wires</li> <li>Turn transceiver "ON"</li> <li>Turn up volume</li> <li>Tune transceiver to signal</li> </ol>
No copy on computer	<ol style="list-style-type: none"> <li>Computer not turned on</li> <li>Program did not load</li> <li>Computer not connected</li> </ol>	<ol style="list-style-type: none"> <li>Turn computer on</li> <li>Re-load program</li> <li>Connect computer</li> </ol>
Computer generating RFI	<ol style="list-style-type: none"> <li>Improper shielding of computer</li> </ol>	<ol style="list-style-type: none"> <li>Install .01 uf caps to ground on all lines to computer from CP-1 and/ or use shielded cable</li> <li>Relocate computer</li> </ol>
Won't copy CW	<ol style="list-style-type: none"> <li>CP-1 filter not in CW position</li> <li>Incorrect tuning of transceiver</li> <li>Computer program set to incorrect mode</li> <li>TTL plug upside down</li> <li>Excessive band noise</li> </ol>	<ol style="list-style-type: none"> <li>Select CW filter on CP-1</li> <li>Tune for full closure of LED bar graph</li> <li>Set program to Morse</li> <li>Reverse plug</li> <li>Decrease RF gain or AF gain</li> </ol>
Won't copy RTTY or ASCII	<ol style="list-style-type: none"> <li>CP-1 filter not in correct position</li> <li>Transceiver in USB mode</li> <li>Incorrect tuning of transceiver</li> <li>Signal is reversed</li> <li>Program not set for correct mode or speed</li> <li>TTL plug upside down</li> </ol>	<ol style="list-style-type: none"> <li>Select proper filter on CP-1 (170 or VAR)</li> <li>Switch to LSB</li> <li>Tune to full closure on bar graph with little or no flicker</li> <li>Change position of normal-reverse switch</li> <li>Select correct mode or speed in program</li> <li>Reverse plug</li> </ol>
Transceiver stuck in key down state while using CW mode on transceiver	<ol style="list-style-type: none"> <li>TTL plug reversed</li> <li>Improper key line selected</li> </ol>	<ol style="list-style-type: none"> <li>Reverse plug</li> <li>Use + key line for transistor-keyed transceiver; use - key line for grid block</li> </ol>
Transceiver stuck in TX state while using RTTY	<ol style="list-style-type: none"> <li>Transceiver in VOX mode</li> <li>Incorrectly wired mic plug</li> </ol>	<ol style="list-style-type: none"> <li>Turn VOX off</li> <li>Rewire mic plug</li> </ol>
Copy seems to run away while receiving RTTY	<ol style="list-style-type: none"> <li>Noise or interference on channel</li> <li>Speed or mode (Baudot, ASCII) incorrect</li> <li>Sending station using reversed tones</li> </ol>	<ol style="list-style-type: none"> <li>If possible change antenna</li> <li>Change mode</li> <li>Use normal-reverse switch</li> </ol>
No tone out from CP-1	<ol style="list-style-type: none"> <li>AFSK level set too low</li> </ol>	<ol style="list-style-type: none"> <li>Adjust AFSK level on rear panel of CP-1</li> </ol>
No tone shift	<ol style="list-style-type: none"> <li>RS-232/TTL switch set to incorrect input</li> </ol>	<ol style="list-style-type: none"> <li>Select correct I/O mode</li> </ol>

# ALIGNMENT PROCEDURE

Each CP-1 has been carefully aligned after an elevated temperature oven burn-in and has passed many tests before it leaves the factory. However, many amateurs like to keep their equipment aligned to specifications. The following describes how to tune your CP-1:

Test equipment needed:

1. Oscilloscope;
2. Audio Frequency Generator;
3. Frequency counter;

## Filter Adjustment:

1. Connect power to the CP-1 and turn the unit 'on';
2. Set filter switch to '170' position;
3. Set your signal generator to 2125 Hz as indicated on your frequency counter. Connect your signal generator to the 'audio in' jack;
4. Adjust R18 and R39 for maximum signal out of the 'mark out' jack on the back of the CP-1 as measured with your scope;
5. Set the frequency generator to 2295 (as indicated on the frequency counter). Adjust R12 and R34 for maximum signal out of the 'space out' jack;
6. Set filter switch to VAR and turn the 'VAR shift' control full clockwise;
7. Set frequency generator to 3125 Hz, adjust R10 and R18 for maximum signal out of 'space out';
8. Adjust 'VAR Shift' full counter-clockwise;
9. Set frequency generator to 2225 Hz, adjust R8, R31 for maximum signal out of 'space out';

## AFSK Adjustment:

1. Set filter switch to '170';
2. On Pin 2 of U14, measure the signal with your frequency counter. It should measure 2125. Adjust R87 to correct frequency output;
3. Ground Pin 2 of the TTL plug on the rear of the CP-1 (make sure the TTL/RS-232 Switch is 'in'). Again on Pin 2 of U14, measure signal with your frequency counter. It should measure 2295. Adjust R89 to correct frequency output.

## IN CASE OF DIFFICULTIES

If, after re-reading this manual, you are having difficulties, a telephone call to the factory Customer Service Department will likely provide a quick answer to your problems. Before calling the factory, try to have the CP-1 in operation near the telephone so that our technician can talk you through the problems. Our telephone number is (206) 775-7373. Office hours are 0800 to 1630 Pacific Time Zone.

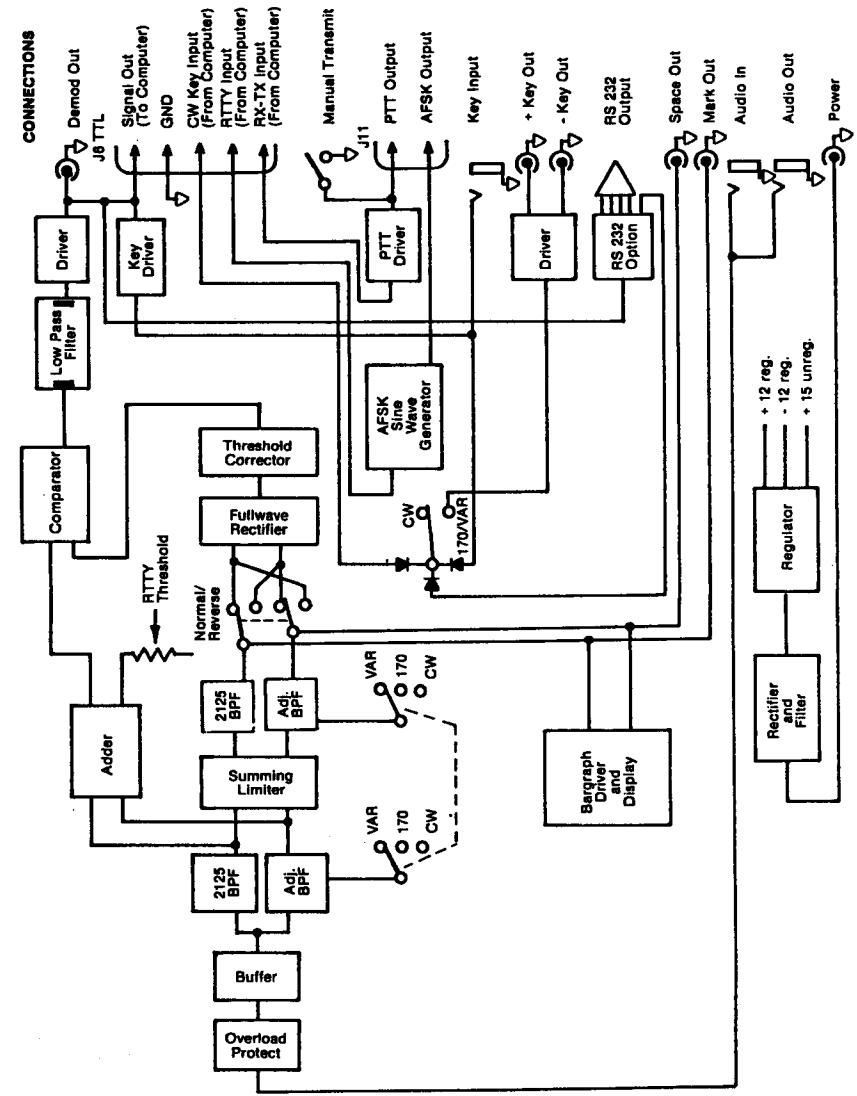

BLOCK DIAGRAM CP-1

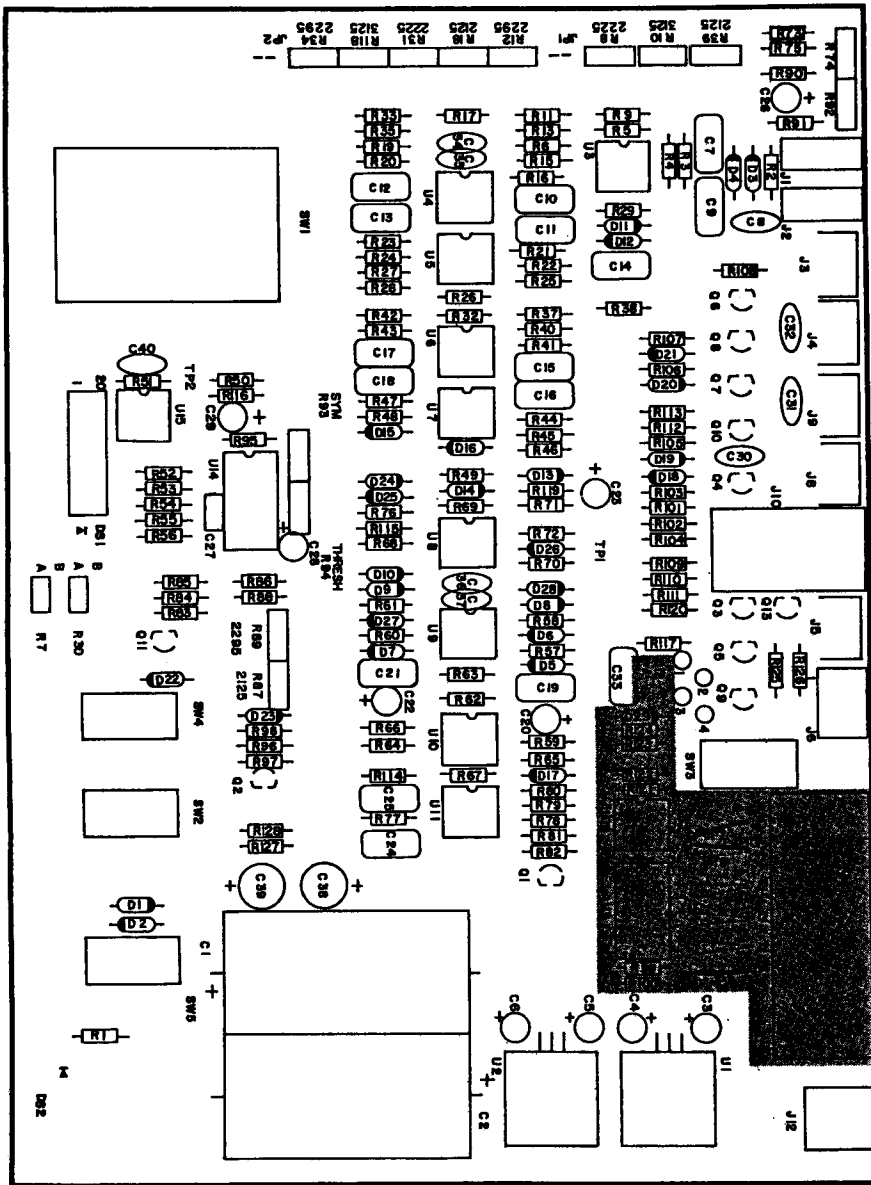

RS-232 OPTION

### PARTS PICTORIAL

### PARTS LIST

#### REFERENCE

#### VALUE

C23	Tantalum Cap. 3.3uf / 25v
C3, 4, 5, 6	Tantalum Cap. 6.8/25
C1, 2	Electrolytic Cap. AX 4700/25 or 1000/25
C38, 39	Electrolytic Cap. RAD 100/25
C22, 20, 26, 29, 28	Electrolytic Cap. RAD 10/25
C31, 32	Ceramic Cap. 500V .01
C8, 30, 34, 35, 36, 37, 40	Ceramic Cap. 50V .01
C10, 11, 12, 13, 14, 15, 16, 17, 18	Mylar Cap. 2% .068
C25	Mylar Cap. 5% .012
C24	Mylar Cap. 5% .1
C27	Mylar Cap. 10% .033
C7, 9, 14, 21, 33	Mylar Cap. 10% .1
R6	Resistor 1/4w. 1% 10k
R15, 40, 19, 42	Resistor 1/4w. 1% 7.32k
R21, 44, 23, 47	Resistor 1/4w. 1% 4.53K
R22, 45, 24, 48	Resistor 1/4w. 1% 27.4k
R16, 41, 43, 20	Resistor 1/4w. 1% 2.26k
R5, 37, 57, 58, 60, 61	Resistor 1/4w. 1% 20k
R52-56	Resistor 1/4w. 5% 680
R81, 99*	Resistor 1/4w. 5% 820
R1, 28	Resistor 1/4w. 5% 750
R76, 65, 114	Resistor 1/4w. 5% 68k
R51	Resistor 1/4w. 5% 620
R117	Resistor 1/4w. 5% 560
R85	Resistor 1/4w. 5% 510k
R80, 90, 91	Resistor 1/4w. 5% 5.1k
R71	Resistor 1/4w. 5% 470k
R78, 126	Resistor 1/4w. 5% 4.7k
R106	Resistor 1/4w. 5% 470
R62, 59	Resistor 1/4w. 5% 39k
R125	Resistor 1/4w. 5% 360
R77, 79	Resistor 1/4w. 5% 33k
R97, 35	Resistor 1/4w. 5% 30k
R17, 38, 11, 33	Resistor 1/4w. 5% 270
R96	Resistor 1/4w. 5% 2.4k
R29	Resistor 1/4w. 5% 200k
R3, 4, 25, 32	Resistor 1/4w. 5% 20k
R98, 108, 101, 109, 113, 119, 115	Resistor 1/4w. 5% 2k
R104, 111	Resistor 1/4w. 5% 18k

**REFERENCE**

**VALUE**

R50	Resistor ¼w. 5% 150
R9, 82, 100*	Resistor ¼w. 5% 1.6k
R105, 13	Resistor ¼w. 5% 15k
R107	Resistor ¼w. 5% 130
R86, 128	Resistor ¼w. 5% 12k
R88	Resistor ¼w. 5% 11k
R68, 66, 63, 64	Resistor ¼w. 5% 100k
R2, 26, 46, 49, 27, 67, 72, 70, 69, 83, 84, 103, 112, 95, 120, 127, 123*	Resistor ¼w. 5% 10k
R121,* 122*	Resistor ¼w. 5% 1k
R102, 110	Resistor ¼w. 5% 27k
R124*	Resistor ¼w. 5% 47k
R73, 75, 116	Resistor ¼w. 5% 2.7k
Q8	Transistor PNP MPSA92
Q9	Transistor NPN MPS6561
Q7	Transistor NPN MPSA42
Q2, 11, 6, 4, 3, 10, 1, 13, 12*	Transistor NPN 2N3904
DS1	LED ARRAY 10 SEG BARGRAPH
DS2	Diode LED MV5025
D20, 21	Diode Power 1N4006
D1, 2, 22	Diode Power 1N4003
D3-19, 23-28, 29*	Diode Signal 1N4448/1N4148
R87, 89	Pot Trim 5k
R18, 39, 10, 34, 12, 94, 118	Pot Trim 500
R92	Pot Trim 10K
R93	Pot trim 25k
R8, 31, 74	Pot Trim 1k
R7, 30	Pot 2Gang 1k-1k
U15	I.C. LED Ladder TL487
U14	I.C. Function Gen. XR2206
U3-11	I.C. Dual Bi-Fet XRO-82
U2	I.C. REGULATOR 7912
U1	I.C. REGULATOR 7812
U12*	I.C. 75150
U13*	I.C. 75152

\*RS232 Option

**APPENDIX "A"**  
**USING MECHANICAL TELETYPE PRINTERS**  
**WITH THE CP-1**

The CP-1 can be used to drive a model 15', 19, 28, or 32 standard teletype machine as a printer for 60 WPM Baudot teletype operation. The CP-1 does not perform any software code or speed conversions. Use one of two possible modifications. The first modification is for CP-1 serial numbers below 1100. The second modification is for serial numbers 1100 and above.

**MODIFICATION #1: (for CP-1 serial numbers BELOW 1100)**

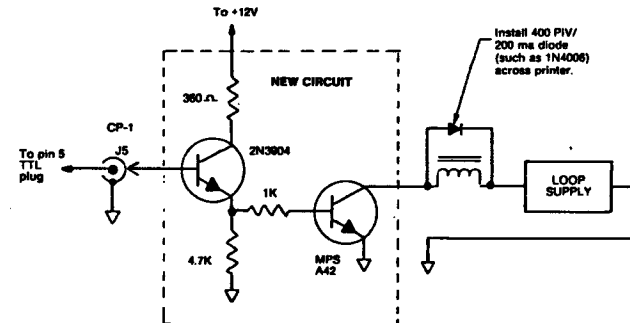

We recommend that you build the circuit onto a small "perf board" that you can mount inside a small chassis (external from the CP-1). If you do not have a +12V source available, we would recommend the AEA model AC-1 power supply.

**MODIFICATION #2: (for CP-1 serial numbers 1100 and ABOVE)**

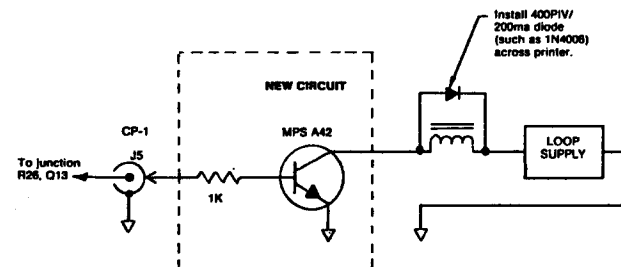

We also recommend that you build this circuitry on a small "perf board" that you can mount outside the CP-1 chassis. No external power source is required as in modification #1.

## APPENDIX "C"

### CP-1 COMPUTER PATCH APPLICATIONS

#### NOTE — NEGATIVE KEYED P.T.T.

Customers who have radios with negative keying Push to Talk lines (such as the Drake T4XC), will have problems with their radios being in a keydown state at all times. There are two modifications to correct this which can be internal to the CP-1.

Modification number 1 will modify the CP-1 so that it will only key negative keyed transceivers. If you wish to use your CP-1 with negative and positive keying transceivers DO NOT perform modification number 1; perform modification number 2.

Modification number 2 will key any rig, positive or negative keyed. For those of you who wish to use your CP-1 with two different rigs (one positive and one negative keyed), perform modification number 2.

## APPENDIX "B"

### MANUFACTURER'S RECOMMENDED MICROPHONE INPUT CONNECTIONS FOR INTERFACING TO THE CP-1

<b>ICOM</b>	(730, 740, 720, 751, 745)	
CP-1 Pin	ICOM Mic. Pin	
1	1	
2	5	
3	6	
4	7	
<b>KENWOOD</b>	(TS 430s, 930s)	(830s, 530s)
CP-1 Pin	Pin	Pin
1	1	1
2	2	2
3	8	3
4	7	4
<b>YAESU</b>	(980, FT-ONE, 102, 77)	(101ZD, 902DM)
CP-1 Pin	Pin	Pin
1	8	2
2	6	3
3	n/c	n/c
4	7	1
<b>DRAKE</b>	(TR-7A)	
CP-1 Pin	TR-7A Mic. Pin	
1	1	
2	2	
3	n/c	
4	3	

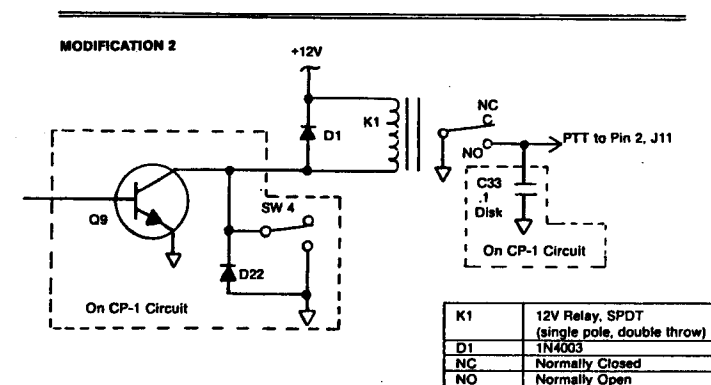
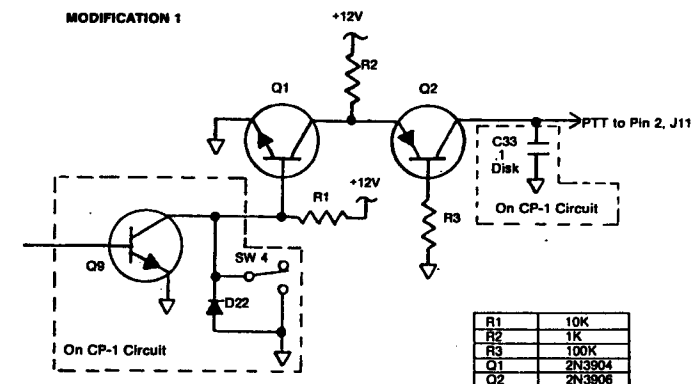

## APPENDIX "C"

### CP-1 COMPUTER PATCH APPLICATIONS

#### NOTE — NEGATIVE KEYED P.T.T.

Customers who have radios with negative keying Push to Talk lines (such as the Drake T4XC), will have problems with their radios being in a keydown state at all times. There are two modifications to correct this which can be internal to the CP-1.

Modification number 1 will modify the CP-1 so that it will only key negative keyed transceivers. If you wish to use your CP-1 with negative and positive keying transceivers DO NOT perform modification number 1; perform modification number 2.

Modification number 2 will key any rig, positive or negative keyed. For those of you who wish to use your CP-1 with two different rigs (one positive and one negative keyed), perform modification number 2.

## APPENDIX "B"

### MANUFACTURER'S RECOMMENDED MICROPHONE INPUT CONNECTIONS FOR INTERFACING TO THE CP-1

ICOM		(730, 740, 720, 751, 745)	
CP-1 Pin		ICOM Mic. Pin	
1		1	
2		5	
3		6	
4		7	

KENWOOD		(TS 430s, 930s)		(830s, 530s)	
CP-1 Pin		Pin		Pin	
1		1		1	
2		2		2	
3		8		3	
4		7		4	

  

YAESU		(980, FT-ONE, 102, 77)		(101ZD, 902DM)	
CP-1 Pin		Pin		Pin	
1		8		2	
2		6		3	
3		n/c		n/c	
4		7		1	

DRAKE		(TR-7A)	
CP-1 Pin		TR-7A Mic. Pin	
1		1	
2		2	
3		n/c	
4		3	



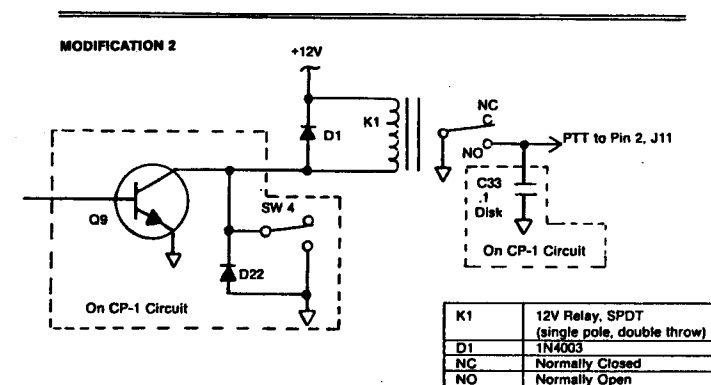
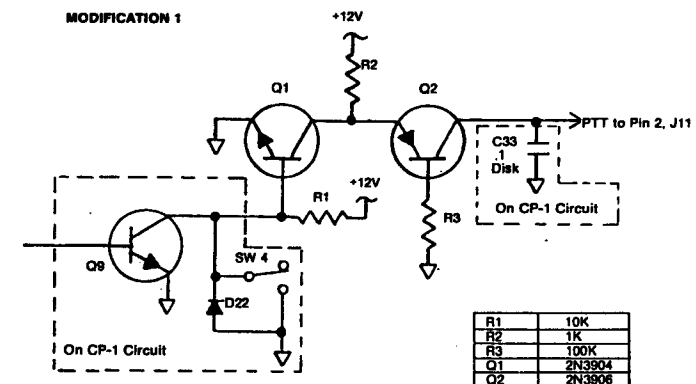

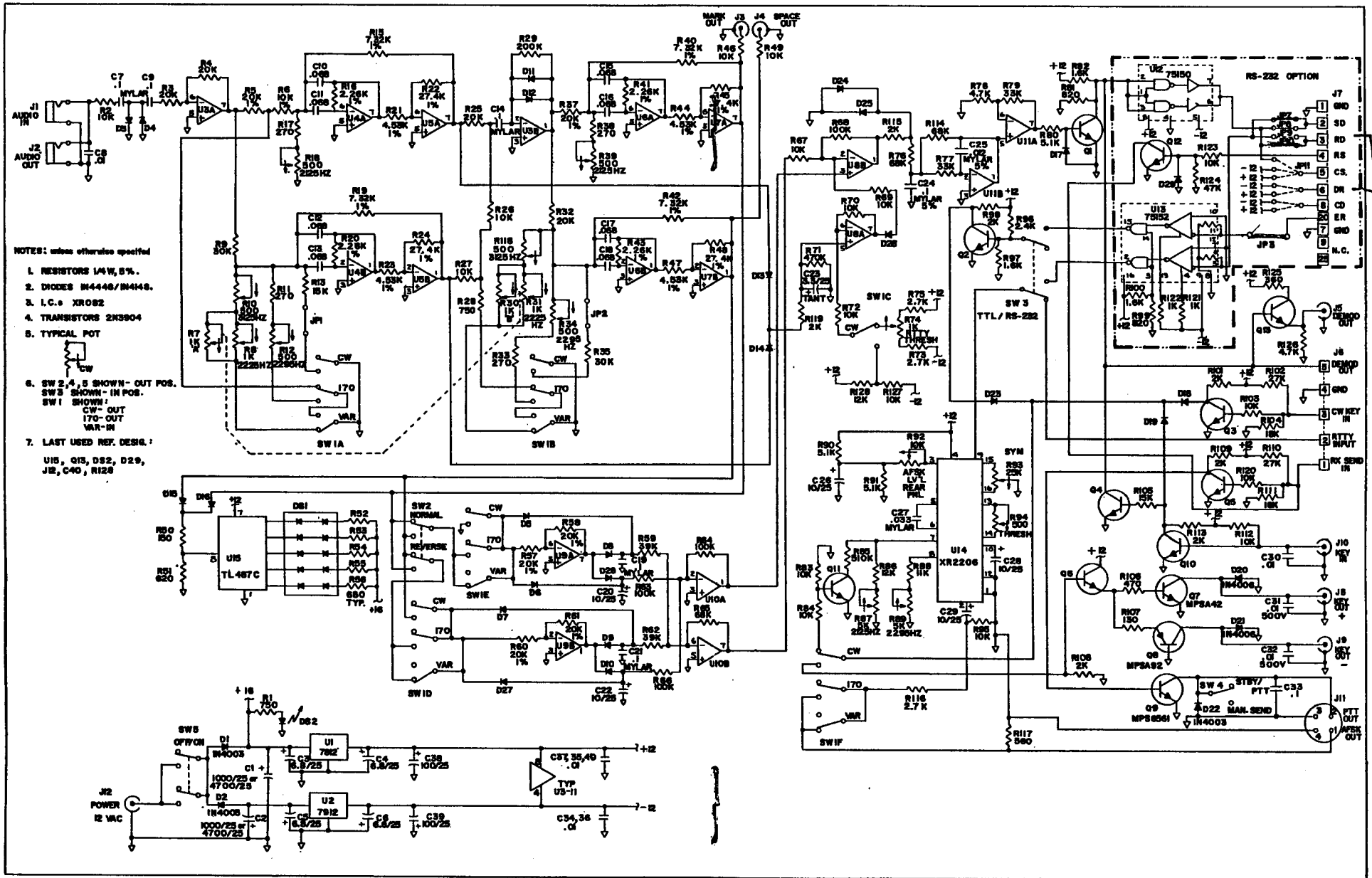
**SCHEMATIC**



# TROUBLE SHOOTING GUIDE

PROBLEM	CAUSE	SOLUTION
No Power	<ol style="list-style-type: none"> <li>Unit not turned on</li> <li>Unit not plugged in</li> <li>No power from wall adaptor</li> </ol>	<ol style="list-style-type: none"> <li>Turn unit on</li> <li>Plug unit in</li> <li>Check supply for 16 VAC</li> </ol>
Bar graph won't flicker	<ol style="list-style-type: none"> <li>Audio input connection incorrect</li> <li>Transceiver not turned on</li> <li>Volume too low from transceiver</li> <li>Incorrect tuning of transceiver</li> </ol>	<ol style="list-style-type: none"> <li>Re-connect wires</li> <li>Turn transceiver "ON"</li> <li>Turn up volume</li> <li>Tune transceiver to signal</li> </ol>
No copy on computer	<ol style="list-style-type: none"> <li>Computer not turned on</li> <li>Program did not load</li> <li>Computer not connected</li> </ol>	<ol style="list-style-type: none"> <li>Turn computer on</li> <li>Re-load program</li> <li>Connect computer</li> </ol>
Computer generating RFI	<ol style="list-style-type: none"> <li>Improper shielding of computer</li> </ol>	<ol style="list-style-type: none"> <li>Install .01 uf caps to ground on all lines to computer from CP-1 and/ or use shielded cable</li> <li>Relocate computer</li> </ol>
Won't copy CW	<ol style="list-style-type: none"> <li>CP-1 filter not in CW position</li> <li>Incorrect tuning of transceiver</li> <li>Computer program set to incorrect mode</li> <li>TTL plug upside down</li> <li>Excessive band noise</li> </ol>	<ol style="list-style-type: none"> <li>Select CW filter on CP-1</li> <li>Tune for full closure of LED bar graph</li> <li>Set program to Morse</li> <li>Reverse plug</li> <li>Decrease RF gain or AF gain</li> </ol>
Won't copy RTTY or ASCII	<ol style="list-style-type: none"> <li>CP-1 filter not in correct position</li> <li>Transceiver in USB mode</li> <li>Incorrect tuning of transceiver</li> <li>Signal is reversed</li> <li>Program not set for correct mode or speed</li> <li>TTL plug upside down</li> </ol>	<ol style="list-style-type: none"> <li>Select proper filter on CP-1 (170 or VAR)</li> <li>Switch to LSB</li> <li>Tune to full closure on bar graph with little or no flicker</li> <li>Change position of normal-reverse switch</li> <li>Select correct mode or speed in program</li> <li>Reverse plug</li> </ol>
Transceiver stuck in key down state while using CW mode on transceiver	<ol style="list-style-type: none"> <li>TTL plug reversed</li> <li>Improper key line selected</li> </ol>	<ol style="list-style-type: none"> <li>Reverse plug</li> <li>Use + key line for transistor-keyed transceiver; use - key line for grid block</li> </ol>
Transceiver stuck in TX state while using RTTY	<ol style="list-style-type: none"> <li>Transceiver in VOX mode</li> <li>Incorrectly wired mic plug</li> </ol>	<ol style="list-style-type: none"> <li>Turn VOX off</li> <li>Rewire mic plug</li> </ol>
Copy seems to run away while receiving RTTY	<ol style="list-style-type: none"> <li>Noise or interference on channel</li> <li>Speed or mode (Baudot, ASCII) incorrect</li> <li>Sending station using reversed tones</li> </ol>	<ol style="list-style-type: none"> <li>If possible change antenna</li> <li>Change mode</li> <li>Use normal-reverse switch</li> </ol>
No tone out from CP-1	<ol style="list-style-type: none"> <li>AFSK level set too low</li> </ol>	<ol style="list-style-type: none"> <li>Adjust AFSK level on rear panel of CP-1</li> </ol>
No tone shift	<ol style="list-style-type: none"> <li>RS-232/TTL switch set to incorrect input</li> </ol>	<ol style="list-style-type: none"> <li>Select correct I/O mode</li> </ol>

# ALIGNMENT PROCEDURE

Each CP-1 has been carefully aligned after an elevated temperature oven burn-in and has passed many tests before it leaves the factory. However, many amateurs like to keep their equipment aligned to specifications. The following describes how to tune your CP-1:

Test equipment needed:

1. Oscilloscope;
2. Audio Frequency Generator;
3. Frequency counter;

## Filter Adjustment:

1. Connect power to the CP-1 and turn the unit 'on';
2. Set filter switch to '170' position;
3. Set your signal generator to 2125 Hz as indicated on your frequency counter. Connect your signal generator to the 'audio in' jack;
4. Adjust R18 and R39 for maximum signal out of the 'mark out' jack on the back of the CP-1 as measured with your scope;
5. Set the frequency generator to 2295 (as indicated on the frequency counter). Adjust R12 and R34 for maximum signal out of the 'space out' jack;
6. Set filter switch to VAR and turn the 'VAR shift' control full clockwise;
7. Set frequency generator to 3125 Hz, adjust R10 and R18 for maximum signal out of 'space out';
8. Adjust 'VAR Shift' full counter-clockwise;
9. Set frequency generator to 2225 Hz, adjust R8, R31 for maximum signal out of 'space out';

## AFSK Adjustment:

1. Set filter switch to '170';
2. On Pin 2 of U14, measure the signal with your frequency counter. It should measure 2125. Adjust R87 to correct frequency output;
3. Ground Pin 2 of the TTL plug on the rear of the CP-1 (make sure the TTL/RS-232 Switch is 'in'). Again on Pin 2 of U14, measure signal with your frequency counter. It should measure 2295. Adjust R89 to correct frequency output.

## IN CASE OF DIFFICULTIES

If, after re-reading this manual, you are having difficulties, a telephone call to the factory Customer Service Department will likely provide a quick answer to your problems. Before calling the factory, try to have the CP-1 in operation near the telephone so that our technician can talk you through the problems. Our telephone number is (206) 775-7373. Office hours are 0800 to 1630 Pacific Time Zone.

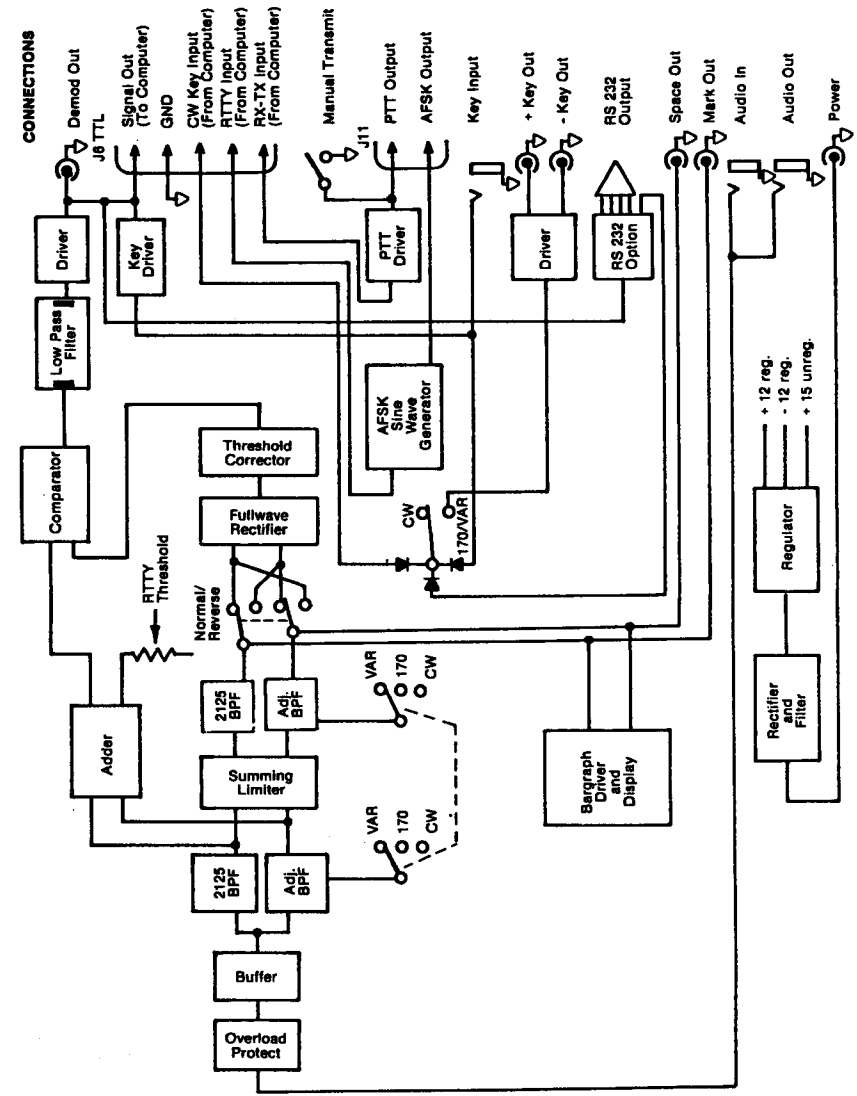

BLOCK DIAGRAM CP-1

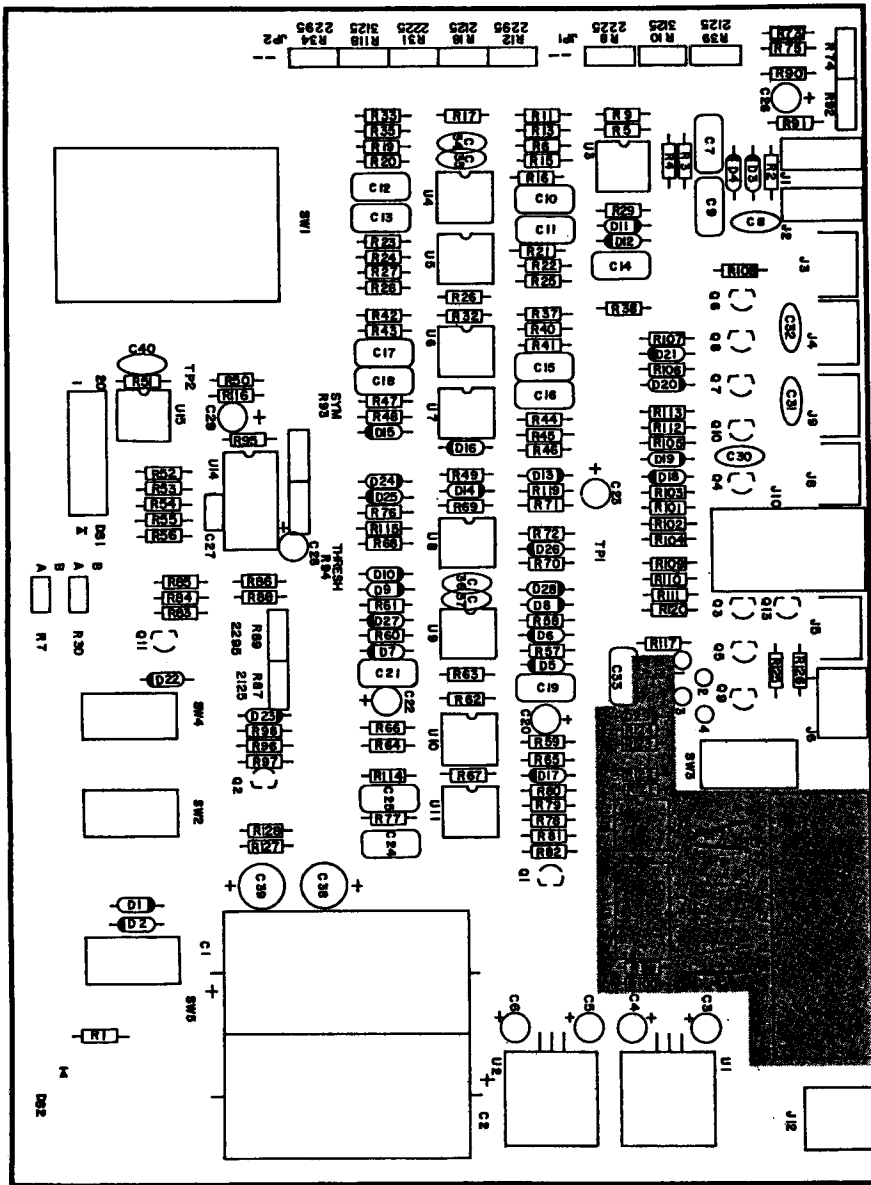

RS-232 OPTION

### PARTS PICTORIAL

### PARTS LIST

#### REFERENCE

#### VALUE

C23	Tantalum Cap. 3.3uf / 25v
C3, 4, 5, 6	Tantalum Cap. 6.8/25
C1, 2	Electrolytic Cap. AX 4700/25 or 1000/25
C38, 39	Electrolytic Cap. RAD 100/25
C22, 20, 26, 29, 28	Electrolytic Cap. RAD 10/25
C31, 32	Ceramic Cap. 500V .01
C8, 30, 34, 35, 36, 37, 40	Ceramic Cap. 50V .01
C10, 11, 12, 13, 14, 15, 16, 17, 18	Mylar Cap. 2% .068
C25	Mylar Cap. 5% .012
C24	Mylar Cap. 5% .1
C27	Mylar Cap. 10% .033
C7, 9, 14, 21, 33	Mylar Cap. 10% .1
R6	Resistor 1/4w. 1% 10k
R15, 40, 19, 42	Resistor 1/4w. 1% 7.32k
R21, 44, 23, 47	Resistor 1/4w. 1% 4.53K
R22, 45, 24, 48	Resistor 1/4w. 1% 27.4k
R16, 41, 43, 20	Resistor 1/4w. 1% 2.26k
R5, 37, 57, 58, 60, 61	Resistor 1/4w. 1% 20k
R52-56	Resistor 1/4w. 5% 680
R81, 99*	Resistor 1/4w. 5% 820
R1, 28	Resistor 1/4w. 5% 750
R76, 65, 114	Resistor 1/4w. 5% 68k
R51	Resistor 1/4w. 5% 620
R117	Resistor 1/4w. 5% 560
R85	Resistor 1/4w. 5% 510k
R80, 90, 91	Resistor 1/4w. 5% 5.1k
R71	Resistor 1/4w. 5% 470k
R78, 126	Resistor 1/4w. 5% 4.7k
R106	Resistor 1/4w. 5% 470
R62, 59	Resistor 1/4w. 5% 39k
R125	Resistor 1/4w. 5% 360
R77, 79	Resistor 1/4w. 5% 33k
R97, 35	Resistor 1/4w. 5% 30k
R17, 38, 11, 33	Resistor 1/4w. 5% 270
R96	Resistor 1/4w. 5% 2.4k
R29	Resistor 1/4w. 5% 200k
R3, 4, 25, 32	Resistor 1/4w. 5% 20k
R98, 108, 101, 109, 113, 119, 115	Resistor 1/4w. 5% 2k
R104, 111	Resistor 1/4w. 5% 18k

**REFERENCE**

**VALUE**

R50	Resistor 1/4w. 5% 150
R9, 82, 100*	Resistor 1/4w. 5% 1.6k
R105, 13	Resistor 1/4w. 5% 15k
R107	Resistor 1/4w. 5% 130
R86, 128	Resistor 1/4w. 5% 12k
R88	Resistor 1/4w. 5% 11k
R68, 66, 63, 64	Resistor 1/4w. 5% 100k
R2, 26, 46, 49, 27, 67, 72, 70, 69, 83, 84, 103, 112, 95, 120, 127, 123*	Resistor 1/4w. 5% 10k
R121,* 122*	Resistor 1/4w. 5% 1k
R102, 110	Resistor 1/4w. 5% 27k
R124*	Resistor 1/4w. 5% 47k
R73, 75, 116	Resistor 1/4w. 5% 2.7k
Q8	Transistor PNP MPSA92
Q9	Transistor NPN MPS6561
Q7	Transistor NPN MPSA42
Q2, 11, 6, 4, 3, 10, 1, 13, 12*	Transistor NPN 2N3904
DS1	LED ARRAY 10 SEG BARGRAPH
DS2	Diode LED MV5025
D20, 21	Diode Power 1N4006
D1, 2, 22	Diode Power 1N4003
D3-19, 23-28, 29*	Diode Signal 1N4448/1N4148
R87, 89	Pot Trim 5k
R18, 39, 10, 34, 12, 94, 118	Pot Trim 500
R92	Pot Trim 10K
R93	Pot trim 25k
R8, 31, 74	Pot Trim 1k
R7, 30	Pot 2Gang 1k-1k
U15	I.C. LED Ladder TL487
U14	I.C. Function Gen. XR2206
U3-11	I.C. Dual Bi-Fet XRO-82
U2	I.C. REGULATOR 7912
U1	I.C. REGULATOR 7812
U12*	I.C. 75150
U13*	I.C. 75152

\*RS232 Option

**APPENDIX "A"**

**USING MECHANICAL TELETYPE PRINTERS**

**WITH THE CP-1**

The CP-1 can be used to drive a model 15', 19, 28, or 32 standard teletype machine as a printer for 60 WPM Baudot teletype operation. The CP-1 does not perform any software code or speed conversions. Use one of two possible modifications. The first modification is for CP-1 serial numbers below 1100. The second modification is for serial numbers 1100 and above.

**MODIFICATION #1: (for CP-1 serial numbers BELOW 1100)**

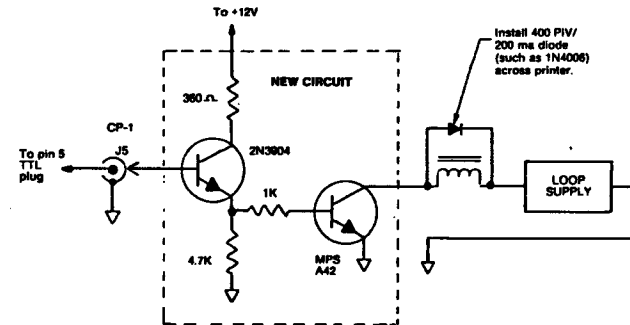

We recommend that you build the circuit onto a small "perf board" that you can mount inside a small chassis (external from the CP-1). If you do not have a +12V source available, we would recommend the AEA model AC-1 power supply.

**MODIFICATION #2: (for CP-1 serial numbers 1100 and ABOVE)**

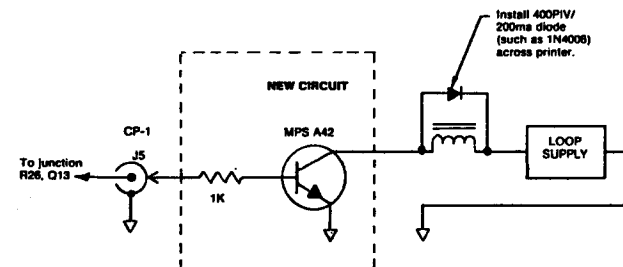

We also recommend that you build this circuitry on a small "perf board" that you can mount outside the CP-1 chassis. No external power source is required as in modification #1.

## APPENDIX "C"

### CP-1 COMPUTER PATCH APPLICATIONS

#### NOTE — NEGATIVE KEYED P.T.T.

Customers who have radios with negative keying Push to Talk lines (such as the Drake T4XC), will have problems with their radios being in a keydown state at all times. There are two modifications to correct this which can be internal to the CP-1.

Modification number 1 will modify the CP-1 so that it will only key negative keyed transceivers. If you wish to use your CP-1 with negative and positive keying transceivers DO NOT perform modification number 1; perform modification number 2.

Modification number 2 will key any rig, positive or negative keyed. For those of you who wish to use your CP-1 with two different rigs (one positive and one negative keyed), perform modification number 2.

## APPENDIX "B"

### MANUFACTURER'S RECOMMENDED MICROPHONE INPUT CONNECTIONS FOR INTERFACING TO THE CP-1

<b>ICOM</b>	(730, 740, 720, 751, 745)	
CP-1 Pin	ICOM Mic. Pin	
1	1	
2	5	
3	6	
4	7	
<b>KENWOOD</b>	(TS 430s, 930s)	(830s, 530s)
CP-1 Pin	Pin	Pin
1	1	1
2	2	2
3	8	3
4	7	4
<b>YAESU</b>	(980, FT-ONE, 102, 77)	(101ZD, 902DM)
CP-1 Pin	Pin	Pin
1	8	2
2	6	3
3	n/c	n/c
4	7	1
<b>DRAKE</b>	(TR-7A)	
CP-1 Pin	TR-7A Mic. Pin	
1	1	
2	2	
3	n/c	
4	3	

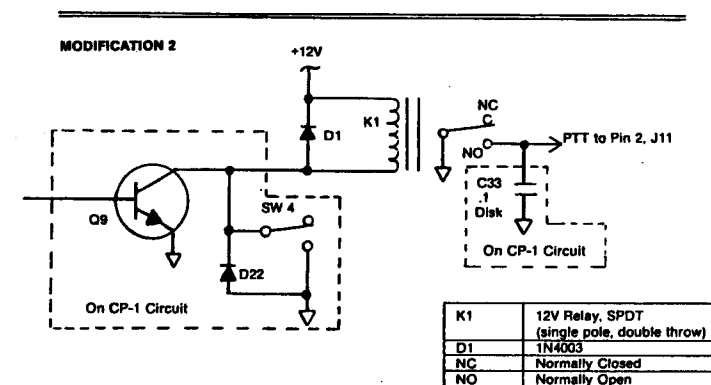
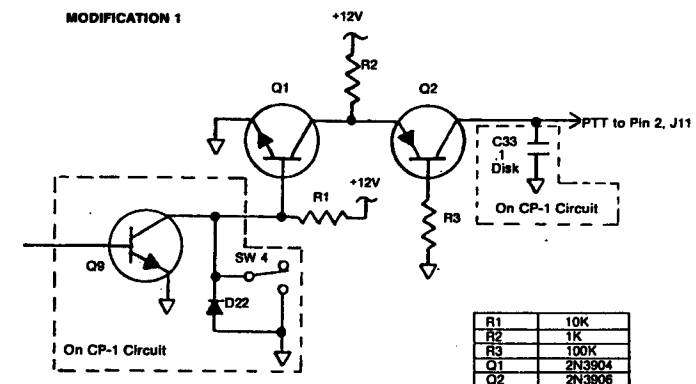

## APPENDIX "C"

### CP-1 COMPUTER PATCH APPLICATIONS

#### NOTE — NEGATIVE KEYED P.T.T.

## APPENDIX "B"

### MANUFACTURER'S RECOMMENDED MICROPHONE INPUT CONNECTIONS FOR INTERFACING TO THE CP-1

<b>ICOM</b>	(730, 740, 720, 751, 745)	
CP-1 Pin	ICOM Mic. Pin	
1	1	
2	5	
3	6	
4	7	
<b>KENWOOD</b>	(TS 430s, 930s)	
CP-1 Pin	Pin	Pin
1	1	(830s, 530s) 1
2	2	2
3	8	3
4	7	4
<b>YAESU</b>	(980, FT-ONE, 102, 77)	
CP-1 Pin	Pin	Pin
1	8	(101ZD, 902DM) 2
2	6	3
3	n/c	n/c
4	7	1
<b>DRAKE</b>	(TR-7A)	
CP-1 Pin	TR-7A Mic. Pin	
1	1	
2	2	
3	n/c	
4	3	

Customers who have radios with negative keying Push to Talk lines (such as the Drake T4XC), will have problems with their radios being in a keydown state at all times. There are two modifications to correct this which can be internal to the CP-1.

Modification number 1 will modify the CP-1 so that it will only key negative keyed transceivers. If you wish to use your CP-1 with negative and positive keying transceivers DO NOT perform modification number 1; perform modification number 2.

Modification number 2 will key any rig, positive or negative keyed. For those of you who wish to use your CP-1 with two different rigs (one positive and one negative keyed), perform modification number 2.

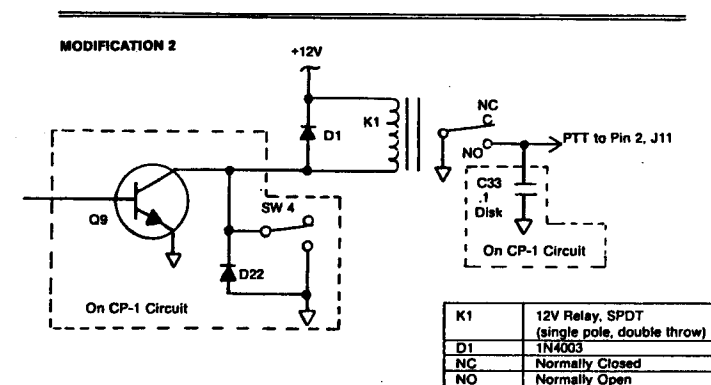
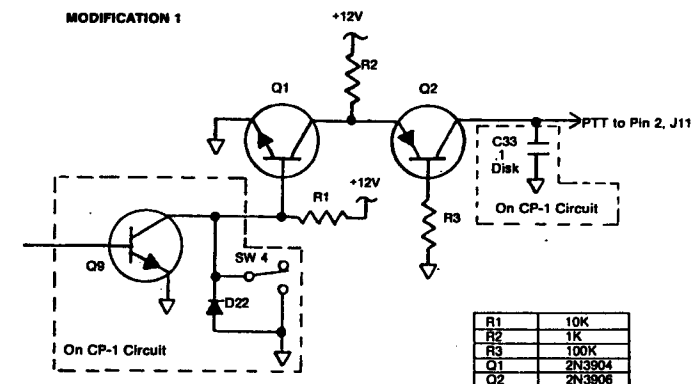

## **AEA COMPUTER PATCH™ INTERFACE MODEL CP-1**

Congratulations on your decision to purchase the AEA Computer Patch™ interface. This equipment was designed to broaden the scope and use of the radio amateur's home computer.

### **DESCRIPTION**

The AEA Computer Patch (CP-1) provides the electronics necessary to connect a personal computer such as the Commodore, Apple, Radio Shack, etc. to your amateur station. The CP-1 uses your receiver audio teletype or CW signals to generate TTL or RS-232 signals for your computer and it generates microphone level AFSK signals for teletype transmissions. For CW transmissions, positive and negative keying lines are provided. A send-receive line for the transmitter push to talk (PTT) circuits is included for automatic transmit-receive.

Specific applications software packages for the CP-1 are available for many of the popular personal computers on the market. Contact your dealer for information regarding software for your particular computer.

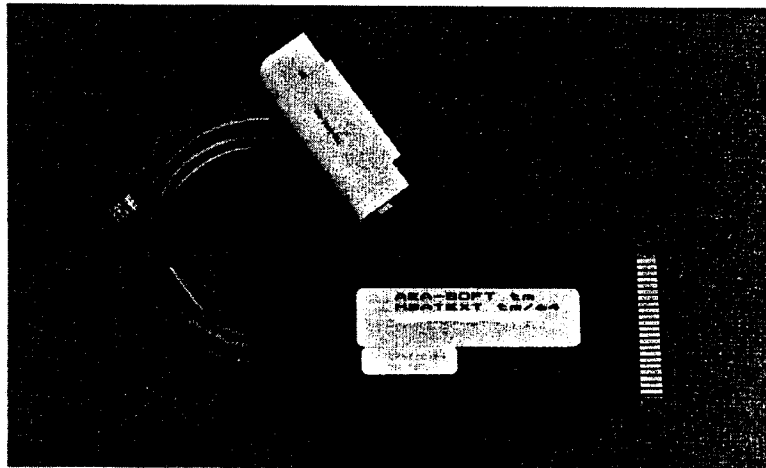

Optional MBATEXT™ Software Package (for Comm-64)

## CONTROLS

### FRONT PANEL

**Power.** On/off switch. With the switch depressed, the CP-1 will be on and the LED power indicator will light.

**Filter.** VAR/170/CW — Selects CW or RTTY operation. Use the VAR (variable) shift rotary control when in the VAR position for RTTY shifts at other than 170 Hz. The variable shift control covers frequency shifts between 100 Hz and 1000 Hz. It is used for tuning non-amateur RTTY signals. Normally, when using your CP-1 in the amateur bands, use the 170 position. CW selects a 800Hz center frequency filter.

**Normal/Reverse.** In the normal position 2125 Hz mark and 2295 Hz space are selected. In reverse, 2295 mark and 2125 space Hz tones are selected. This feature only affects receive. If you select reverse, your transmitted tones will still be 2125 Hz mark and 2295 Hz space. The reverse mode is useful for copying stations that are inadvertently transmitting inverted.

**Tune.** Magic eye style bar graph indicator for CW and RTTY signal tuning.

**VAR Shift.** Adjusts RTTY shift of upper frequency tone from 100 Hz to 1000 Hz. This control is only effective when the VAR filter is selected.

**STBY/PTT, Manual TX.** This control will allow you to manually activate the PTT line of your transceiver, (provided you have hooked up a cable between the mic output of the CP-1 and the mic input of your transceiver). When the switch is in the 'in' position, your transceiver will be in a transmit state.

### REAR PANEL

**Threshold — Squelch Adjustment.** Sets minimum signal level for CP-1 operation. This control only affects RTTY reception. It can be used as an anti-space circuit (so you only get print when you are receiving a RTTY signal). To set the level, tune to a dead air spot on the band and turn the control full clockwise viewing the unit from the back. With the RTTY filter selected on the CP-1, slowly start turning the 'threshold' control counter-clockwise. When garbled copy starts appearing on the screen, turn the control a bit clockwise.

**Note:** Your volume control should be set at an easy listening point. If you have it set too high or have too much line noise, you may not be able to completely eliminate garbage copy under no-signal conditions.

**AFSK Level.** Sets the AFSK output level. The level is variable between 0 and 200 mv pp. For transceivers with pre-amplified microphones (such as ICOM), set the control at maximum signal out. The level is preset to 30 mv pp. If more output is required, reduce R116 value, but no lower than 560 ohms.

## CONNECTIONS

### POWER

The CP-1 requires a 12-16 VAC power source (supplied with unit) capable of supplying 400 ma. The power connector is a 2.1 mm center pin coaxial type.

### AUDIO

The audio IN/OUT jacks are 3.5 mm phone jacks and are in parallel in the CP-1. The audio IN (input) jack is used to provide the CP-1 with audio (CW, RTTY) signals from the transceiver. Receiver audio should be taken from the external speaker output of your receiver. Do not draw audio from the headphone, tape out, or phone patch out jacks; because frequently, manufacturers will install some resistance in the leads to cut down audio level or impedance match.

### KEY IN

Straight key, or **positive** keyer input. In the CW mode, this input keys the + and - keying transistor switches. In the RTTY mode, it generates narrow shift AFSK (about 50 Hz) for CW identification in RTTY. It is also useful for Morse sending practice by monitoring your fist on the CRT attached to your computer (providing you have Morse receiving software). This input is only active when the CP-1 is turned on.

### SCOPE OUT

The mark and space filter outputs are provided at these connections for tuning RTTY signals with the aid of an X-Y scope.

### KEY OUT/ +, -

The + and - keyed outputs are for CW keying of the transmitter. The + key output is for use with transistor (direct) keying. The key output is for use with transmitters using grid block keying. Connect a line from one of these jacks to the key/input on your transceiver. If you do not know whether your rig is + keyed or - keyed, then simply insert the cable into either the + or the - key outputs. If you suddenly hear your side tone go on and stay on, then insert the cable into the opposite key out jack. Remember to place your mode switch on your radio in the CW mode when performing this test.

### DEMOD OUT

TTL level low on space tone or CW (0v). High mark tone or lack of signal (5v). This output can also be used to drive a current loop circuit. Appendix A shows a loop keying circuit that will perform the task of driving a current loop. If you wish, you could also purchase the AEA model RS-232-1 option that will perform as an isolated current loop keying circuit.



## TTL (Also see RF Shielding, page 7)

To computer, 5 pin connector (supplied), TTL levels

- Pin 1 - PTT; active low send
- Pin 2 - RTTY input; space low, mark high
- Pin 3 - CW input; active low
- Pin 4 - Ground
- Pin 5 - Demodulator output; space low, mark high

**Note:** This connector is wired with Pin 5 being on the left hand side of the connector viewing the unit from the rear.

## RS-232 I/O (OPTION)

Provides RS-232 level demodulator output and RTTY or CW input. Internal jumpers provided for 'terminal' or 'computer' drive. This is strictly an RS-232 level shift, it will not drive a printer or other such devices, as the CP-1 is strictly a modem. It has no software for built-in conversions.

## TRANSCEIVER OUTPUT:

This connector handles all of the 'interfacing' to your transmitter

- Pin 1 - AFSK out—Audio Frequency Shift Keying. This line is connected to the (mic) audio input of your transceiver.
- Pin 2 - PTT out. This is connected to the high side of the PTT line of your transceiver. Wiring examples are given in Appendix B for some of the more popular transceivers. If you have a transceiver with negative PTT (such as the Drake T4XC) then follow Appendix C.
- Pin 3 - PTT GND. This is connected to the PTT ground side of your transceiver. Some transceivers require a separate ground and others do not. If yours does, then wire up pin 3 to your PTT ground side. If yours does not, do not wire up pin 3.
- Pin 4 - Shield. This is the shield of the audio lead. Connect to the ground pin of your mic connector. This pin also normally serves as the ground side of your PTT circuit. See above (Pin 3).

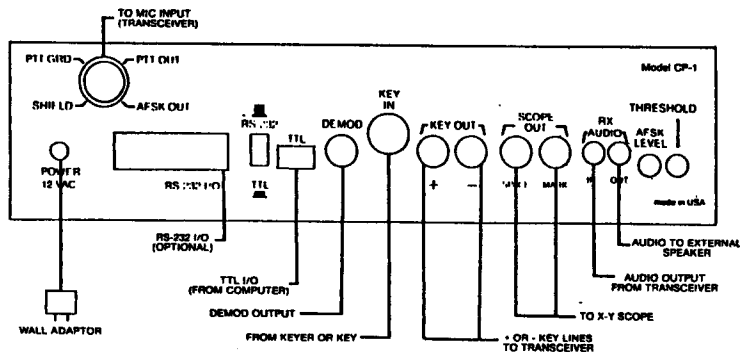

REAR PANEL CONNECTIONS

## OPERATION

There are three filter selections available from the front panel. Two are for RTTY teletype use, one is for CW use. The position marked 170 is for use with amateur and commercial 170 Hz shift teletype (either Baudot or ASCII) with the mark tone at 2125 Hz and the space tone at 2295 Hz. In the VAR position, the space tone filter is tunable with the VAR shift control from 2225 Hz to 3125 Hz giving a frequency shift range of 100 Hz to 1000 Hz.

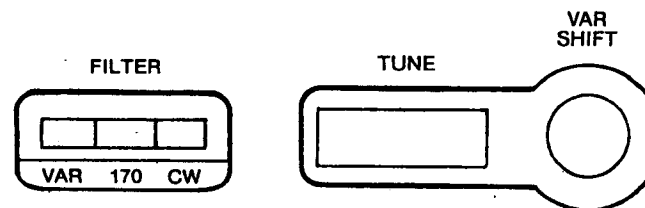

## CW

Press the front panel filter switch CW position. This selects the 800 Hz CW input filters and the positive and negative transmitter keying circuits.

Set your receiver audio to a comfortable level and tune in a CW signal for maximum closure. What we mean by maximum closure is that you are getting peak closure of the bar graph display. If you set your volume at a particular level and tuned across a signal and the bar graph closes to a maximum of 8 LED's, the peak closure is 8 LED's. If you turn your volume up, the closure may be 10 LED's, however, when driving the CP-1 with a very loud signal; it is possible to over drive the filters with noise. It is best to run just enough audio to get the job done, 6 to 8 LED's is about right. If you see the bar graph flicker with just noise on the frequency, then you probably have the volume up too high.

Some software programs will automatically activate the PTT line when you place the program into transmit. If yours does not, use either the Manual RX/TX Switch on the front of the CP-1 or a foot switch.

## TELETYPE RECEIVE

Both VAR and 170 switch positions are used for teletype (Baudot or ASCII) operation. Pressing either of these switches selects the teletype filters and disconnects the CW keying lines from the CW keying transistors.

Most amateur teletypes use standard 170 Hz tone spacing (2125 Hz mark, 2295 Hz space tones). Use the 170 position for standard amateur operation.

To tune amateur HF teletype signals, set your receiver to lower sideband, set the audio to a comfortable level and slowly tune your receiver for a teletype signal. Tune for peak bar graph closure and minimum flicker. If the LED bar graph flickers on mark-space transitions, retune until the flickering stops.

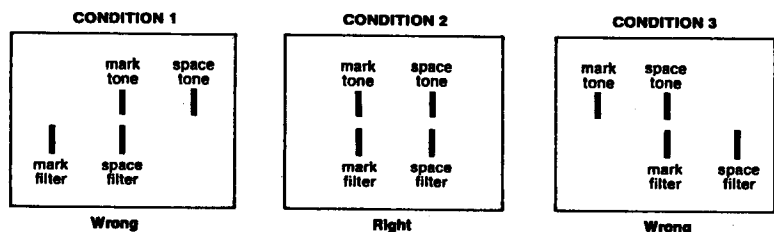

When you tune your receiver dial, you want to match the RTTY mark and space tone frequencies up with the respective bandpass filters in the CP-1, as indicated in condition 2. This proper tune condition will be indicated by the magic-eye style bar graph indicator display with a peak closure of no more than 6 or 8 bars lit (back off on the volume if you have more) and no blinking as the tones shift back and forth. You will get a false tuning indication as shown in conditions 1 and 3, if a peak closure results in a blinking display as the tones shift back and forth. With practice, you will learn to lock onto a properly tuned condition very quickly and you will gain a deep appreciation for our unique tuning indicator.

For shifts other than 170 Hz, use the VAR position. The VAR position uses the VAR shift control to adjust for tone shifts between 100 Hz and 1000 Hz. To use the variable position, first depress the VAR button, turn the variable shift control full clockwise and tune across the unknown RTTY signal. Watching the bar graph, tune to the lower pitch frequency of the two tone RTTY signal. Tune so the LED bar graph is at peak closure, but flickering. Now adjust the variable shift control counter-clockwise until you achieve peak closure with no flickering.

## NORMAL-REVERSE SWITCH

Some stations use reverse mark and space tone frequencies, usually accidentally. If you are sure of the speed and shift of the received station and receiving 'garbage', try the reverse position.

## TELETYPE TRANSMIT

If you are using the RS-232 option, you may have to manually switch your transceiver to transmit. Again, this depends on your particular software. The normal computer TTL inputs can be used for automatic send/receive switching under software control. The 'AFSK out' level may be adjusted with the rear panel AFSK level control. This level is preset to 30 mv pp, however, it can be adjusted to 200 mv pp for those of you who own rigs with a preamp mic such as the ICOM transceivers.

If you own a transceiver with a RTTY mode position, then you may desire to modify your CP-1 as per Appendix D to use FSK. If you wish to use AFSK, then you must use lower sideband and use the mic input of the transceiver. For those of you who wish to use 850 Hz shift on transmit, refer to Appendix E on how to modify your CP-1.

## 300 BAUD OPERATION

The low pass filter is optimized for CW and RTTY rates less than 100 baud. To use 300 baud, parallel R77 with a 16 K ohm ¼ watt resistor.

## WARNING

Most amateur transmitters are NOT capable of 100% duty cycle full power input on Radio Teletype (RTTY) transmission). If your transmitter manual does not have operating instructions for RTTY, we suggest one-third to one-half the normal CW input power level. Be sure to disconnect your microphone to prevent sounds in the shack from being transmitted.

## CW IDENTIFICATION

In teletype operation the AFSK mark and space tones are 2125 and 2295 Hz, respectively. If the CW input line is activated during RTTY operations, a narrow shift (approximately 50 Hz) AFSK CW signal is generated. This can be used for narrow shift CW identification.

## RF SHIELDING

The CP-1 has been designed and tested to comply with FCC rules for a class-B computing device under specifications outlined in part 15, subpart J.

The CP-1 is far better than the FCC requirements because of the necessary close proximity of HF receiving equipment. To assure maximum rejection of RF interference, be sure to use only well shielded interface cables between the CP-1 and your computer and transceiver.

If computer "hash" is present after using shielded cables, try changing the physical location of the computer and/or CP-1 relative to the receiver. Under particularly difficult situations, try placing the CP-1 and computer on a different 110 VAC circuit from the one your transceiver is using.

**NOTE:** To avoid interference with other electronic equipment in your home or other's homes, make sure you make or procure cables which are shielded, and have the shield connected to ground. AEASOFT™ software cables are recommended and have the needed shield.

## BASIC RTTY THEORY

Radioteletype (abbreviated RTTY) is a form of telegraphic communication employing typewriter-like machines for generating a coded set of electrical impulses when a key is pressed on the keyboard and converting a received set of such impulses into the corresponding character.

With the application of home computers to the amateur's use, we are now able to use a computer to do all decoding and generation of the coded set of electrical impulses. Further, computers require practically no maintenance, whereas old teletype gear required frequent oiling and maintenance.

More important than the computer, is the terminal unit (TU) which handles the conversion of the two-toned signal into a string of DC high and low (1 or 0) level signals. This is called a demodulator because it demodulates the tones into something the computer can understand. A TU should also have some method of generating a two-tone signal from a high/low going signal. This is called a modulator. When a demodulator and modulator are combined into the same package, it is referred to as a modem.

The CP-1 is a modem. The demodulator in the CP-1 employs a sophisticated dual filtering system and an automatic threshold circuit. The two tones (received from the air) are separately demodulated and then fed into a threshold circuit. The threshold circuit then automatically decides which is the stronger of the two filter signals and allows that one to pass. However, when one of the signals fade out or is jammed or removed altogether, the threshold circuit automatically switches over to the clear tone.

This sort of a system is especially nice under poor signal conditions when a condition called selective fading is present. Selective fading is when one of the RTTY tones fades away and then reappears. When this happens, the threshold circuit automatically adjusts to the other tone. Another nice feature of the threshold circuit is if interference eliminates one of the RTTY tones or if one of the tones is jammed, the threshold circuit will again switch over to the tone remaining in the clear.

It is obvious that a dual filtering system which uses both filters and a threshold circuit, will perform much better than a single filter system or a phase-locked loop system that uses only one filter for decoding.

U.S amateurs are allowed to use 60 wpm, 67 wpm, 75 wpm, and 100 wpm Baudot, and 110 baud and 300 baud ASCII on the HF bands. ASCII is a code made up of 7 bits and 1 parity bit. However, the parity bit is left out. Baudot is made up of a 5 bit code and includes a start bit and stop bit. The start bit sets the sending and receiving mechanism in

operation. The stop bit indicates the end of the operation (character) and sets the machines up for the next character. Since both RTTY Baudot and RTTY ASCII are teletype sent over a radio, technically both are RTTY. However, RTTY Baudot is usually referred to as RTTY and RTTY ASCII is referred to as ASCII. In this manual when we say RTTY we mean both Baudot and ASCII. This may sound a bit confusing, but if you just remember that both are 'radio teletype' that are made up of different codes; you should not remain confused for too long. Most amateurs you find will be running 60 wpm (45 baud). (A baud is defined as the number of pulses per second). The North American standard is to use mark as 2125 and space as 2295 (for a shift of 170 Hz). Generally, a good place to find RTTY/ASCII signals is on the 20 meter band between 14.080 and 14.100. The best thing to do is listen in on some QSO's in action and see how they operate before getting on the air yourself. To do this with the CP-1 you must use lower sideband and use AFSK (Audio Frequency Shift Keying). You who have a rig with a RTTY position on your mode switch may want to use FSK (Frequency Shift Keying). The CP-1 is set up for AFSK, however, you can modify it to do FSK (see Appendix D). The CP-1 has an internal AFSK generator. This is called the modulator. It generates the two-tone signal upon command. This signal is then fed to your microphone input on your transceiver.

## TABLE OF CONTENTS

DESCRIPTION .....	1
CONTROLS.....	2
CONNECTIONS.....	3
OPERATION .....	5
RF SHIELDING.....	7
BASIC RTTY THEORY.....	8
SCHEMATIC .....	10
TROUBLE SHOOTING GUIDE.....	12
ALIGNMENT PROCEDURE .....	13
IN CASE OF DIFFICULTIES .....	14
BLOCK DIAGRAM .....	15
PARTS PICTORIAL.....	16
PARTS LIST .....	17
APPENDIX "A" .....	19
APPENDIX "B" .....	20
APPENDIX "C" .....	21
APPENDIX "D" .....	22
APPENDIX "E" .....	23
WARRANTY	